



US Army Corps
of Engineers
Alaska District

Public Notice of Application for Permit

FAIRBANKS FIELD OFFICE
Regulatory Division (1145)
CEPOA-RD
1046 Marks Road
Fort Wainwright, Alaska 99703

PUBLIC NOTICE DATE:	March 20, 2025
EXPIRATION DATE:	April 21, 2025
REFERENCE NUMBER:	POA-1979-00412
WATERWAY:	Knik Arm

Interested parties are hereby notified that a Department of the Army permit application has been received for work in waters of the United States as described below and shown on the enclosed project drawings.

All comments regarding this public notice should be sent to the address noted above. If you desire to submit your comments by email, you should send it to the project manager's email as listed below or to regpagemaster@usace.army.mil. All comments should include the public notice reference number listed above.

All comments should reach this office no later than the expiration date of this public notice to become part of the record and be considered in the decision. Please contact Gwen Jacobson at (907) 347-5802, toll free from within Alaska at (800) 478-2712, or by email at Gwendolyn.A.Jacobson@usace.army.mil if further information is desired concerning this public notice.

APPLICANT: Tom Adams, Matanuska Susitna Borough; 350 E. Dahlia Ave, Palmer, AK, 99645; (907) 861- 7751; tom.adams@mastugov.us

AGENT: Taylor Meyers, Moffatt & Nichol; 880 H Street Suite 208, Anchorage, AK 99501; (206) 622-0222; Tmeyers@moffattnichol.com

LOCATION: The project site is located within Section 25, T. 14 N., R. 4 W., Seward Meridian; Latitude 61.2697, Longitude -149.9189; 2800 South Don Young Road, in Wasilla, Alaska.

PURPOSE: The applicant’s stated purpose is to construct a new sloped haulout ramp for marine barges and other watercraft at Port Mackenzie. The ramp would allow barges to be grounded on a rising tide and then pulled up onto uplands for storage and inspection. The proposed haulout is intended to improve existing infrastructure to increase frequency and diversity of use at the Port, thereby reducing land transportation from other ports; and to serve as a back-up facility in the event of disruption to the Port of Alaska or road or rail supply lines.

PROPOSED WORK: The applicant proposes to discharge 10,300 cubic yards of rip rap and 49,300 cubic yards of sand and gravel fill into 2.8 acres of Knik Arm below the high tide line (HTL). Prior to ramp installation, approximately 3,050 cubic yards of riprap and 38,500 cubic yards of soft marine deposits would be excavated from the same 2.8-acre footprint. Excavated riprap would be temporarily stockpiled on the Port uplands and reused to armor the toe of the new ramp, resulting in a net volume of 43,000 cubic yards of fill. Excavated sediments would be disposed of at a nearby upland disposal facility.

Table 1. Excavation and fill volumes

	Above High Tide Line (cy)	Below High Tide Line (cy)
Excavation	400	38,500
Rip rap removal	750	3,050
Fill (sediment/gravel)	600	49,300
Fill (rip rap) ¹	150	10,300

¹ May include riprap previously removed from embankment and stockpiles within the Port's adjacent upland area.

Following excavation activities, sand and gravel would be trucked in from a nearby upland borrow pit (Lorraine Pit) and end-dumped starting just above the high tide line and moving seaward. As fill advances seaward, work would be timed with low tides. Sand and gravel fill would likely be compacted with a vibratory compactor. The toe and sides of the fill would be sloped and armored with riprap.

The project is anticipated to take up to 5 months of work, between May and November, depending on ice levels. Construction activities would include excavation, riprap removal, and placement of fill and riprap, and require the use of an excavator, trucks, a front end loader, and vibratory plate or smooth drum compactor. Work would occur from land and in the dry when feasible. If in-water work would occur, it would be limited to the placement of rock or fill with a front-end loader and/or excavation activities.

All work would be performed in accordance with the enclosed plan (sheets 1-5), dated March 17, 2025.

APPLICANT PROPOSED MITIGATION: The applicant proposes the following mitigation measures to avoid, minimize, and compensate for impacts to waters of the United States from activities involving discharges of dredged or fill material.

a. Avoidance: The applicant stated that the ramp has been designed to provide the smallest feasible footprint while meeting the project goals. Given the nature of the project as a

barge haulout facility and its dependence on marine access, avoidance altogether is impracticable.

b. Minimization: The applicant stated that the project footprint was designed and oriented to be as minimal as possible given the project purpose, tidal conditions, vessel drafts, and operational slope requirements. The proposed haulout was designed to only be accessible during mid-to-high tides greater than +24 feet MLLW. Additionally, construction would be performed in the dry, including at lower tides, to the extent feasible. The applicant anticipates that the entirety of the ramp could be constructed in the dry at low tides, but for the purpose of this application, has assumed that some in-water work may be required. For further minimization, the applicant intends to use the following best management practices (BMPs):

- Excavated material would be stockpiled and disposed of in upland sites to prevent erosion and subsequent sedimentation into waters of the U.S.
- Fill material would be clean and free from petroleum products and contaminants in toxic amounts.
- A spill prevention, control, and countermeasures (SPCC) plan would be prepared and used during all construction operations. The plan would include the following:
 - BMPs, responsive actions in the event of a spill or release, notification and reporting procedures, and management elements, such as personnel responsibilities, project site security, site inspections, and training.
 - Measures to prevent the release or spread of hazardous materials used during site activities or encountered on site during construction but not identified in contract documents, including any hazardous materials that are stored, used, or generated during excavation activities. These items generally include, but are not limited to, gasoline, diesel fuel, and oils.
 - Applicable spill response equipment and materials to be maintained at the job site.
 - Reasonable precautions and controls to be used to prevent incidental and accidental discharge of petroleum products or other hazardous substances.
 - Fuel storage and handling activities for equipment so there is no petroleum contamination of the ground, subsurface, or surface waterbodies.
 - Spill response equipment and supplies to be used immediately to contain and cleanup oil, fuel, hydraulic fluid, antifreeze, or other pollutant spills; any spill amount would be reported in accordance with applicable state requirements.
 - Restrictions on construction equipment being operated below the HTL (or other noted jurisdictional line within applicable federal and state permits) if equipment is leaking fuel, oil, hydraulic fluid, or any other hazardous material. Equipment would be inspected on a daily basis for leaks. If leaks are found, the equipment would be restricted from use and pulled from service until the leak is repaired.

c. Compensatory Mitigation: The applicant believes that no compensatory mitigation should be required due to the location of the project at an existing Port, the lack of sensitive habitat such as submerged aquatic vegetation or wetlands, and minimization of impacts to the extent feasible.

WATER QUALITY CERTIFICATION: A permit for the described work will not be issued until a certification or waiver of certification, as required under Section 401 of the Clean Water Act (Public Law 95-217), has been received from the Alaska Department of Environmental Conservation.

CULTURAL RESOURCES: The latest published version of the Alaska Heritage Resources Survey (AHRS) has been consulted for the presence or absence of historic properties, including those listed in or eligible for inclusion in the National Register of Historic Places. There are no cultural resources in the permit area or within the vicinity of the permit area. The permit area has been determined to be the project footprint within waters of the U.S. and immediately adjacent upland areas used for construction staging. Consultation of the AHRS constitutes the extent of cultural resource investigations by the U.S. Army Corps of Engineers (Corps) at this time, and we are otherwise unaware of the presence of such resources. The Corps has made a No Potential to Cause Effects determination for the proposed project. Consultation with the State Historic Preservation Office (SHPO), Federally recognized Tribes, and other consulting parties is not required. However, any comments SHPO, Federally recognized Tribes, and other consulting parties may have concerning presently unknown archeological or historic data that may be lost or destroyed by work under the requested permit will be considered in our final assessment of the described work.

ENDANGERED SPECIES: The project area is within the known or historic range of the short-tailed albatross (*Phoebastria albatrus*), and the Cook Inlet distinct population segment (DPS) of beluga whale (*Delphinapterus leucas*) and its critical habitat.

We have determined the described activity may affect, but is not likely to adversely affect, the Cook Inlet distinct population segment (DPS) of beluga whale (*Delphinapterus leucas*) and their designated critical habitat. Additionally, we have determined that the described activity would have no effect on the short-tailed albatross (*Phoebastria albatrus*). We will initiate the appropriate consultation procedures under section 7 of the Endangered Species Act with the U.S. Fish and Wildlife Service and the National Marine Fisheries Service (NMFS). Any comments they may have concerning endangered or threatened wildlife or plants or their critical habitat will be considered in our final assessment of the described work.

ESSENTIAL FISH HABITAT: The Magnuson-Stevens Fishery Conservation and Management Act (Magnuson-Stevens Act), as amended by the Sustainable Fisheries Act of 1996, requires all Federal agencies to consult with the NMFS on all actions, or proposed actions, permitted, funded, or undertaken by the agency, that may adversely affect Essential Fish Habitat (EFH).

The project area is within mapped EFH for Chinook (*Oncorhynchus tshawytscha*), chum (*Oncorhynchus keta*), coho (*Oncorhynchus kisutch*), sockeye (*Oncorhynchus nerka*), and pink salmon (*Oncorhynchus gorbuscha*); as well as the following pacific groundfish species: arrowtooth flounder (*Atheresthes stomias*), English sole (*Parophrys vetulus*), flathead sole (*Hippoglossoides elassodon*), northern rock sole (*Lepidopsetta polyxystra*), Pacific cod (*Gadus macrocephalus*), rex sole (*Glyptocephalus zachirus*), sablefish (*Anoplopoma fimbria*), southern rock sole (*Lepidopsetta billineta*), starry flounder (*Platichthys stellatus*), walleye pollock (*Theragra chalcogramma*), and yellowfin sole (*Limanda aspera*).

We are currently gathering information regarding these species and have yet to make a determination of effect. Should we find that the described activity may adversely affect EFH for the species listed above, we will follow the appropriate course of action under Section 305(b)(2) of the Magnuson-Stevens Act. Any comments the NMFS may have concerning EFH will be considered in our final assessment of the described work.

TRIBAL CONSULTATION: The Corps fully supports tribal self-governance and government-to-government relations between Federally recognized Tribes and the Federal government. Tribes with protected rights or resources that could be significantly affected by a proposed Federal action (e.g., a permit decision) have the right to consult with the Corps, Alaska District, on a government-to-government basis. Views of each Tribe regarding protected rights and resources will be accorded due consideration in this process. This public notice serves as notification to the Tribes within the area potentially affected by the proposed work and invites their participation in the Federal decision-making process regarding the protected Tribal rights or resources. Consultation may be initiated by the affected Tribe upon written request to the District Commander. This application is being coordinated with federally recognized tribes and other consulting parties. Any comments federal recognized tribes and other consulting parties may have concerning presently unknown archeological or historic data that may be lost or destroyed by the work under the requested permit will be considered in the Corps final assessment of the described work.

PUBLIC HEARING: Any person may request, in writing, within the comment period specified in this notice, that a public hearing be held to consider this application. Requests for public hearings shall state, with particularity, reasons for holding a public hearing.

EVALUATION: The decision whether to issue a permit will be based on an evaluation of the probable impacts, including cumulative impacts of the proposed activity and its intended use on the public interest. Evaluation of the probable impacts, which the proposed activity may have on the public interest, requires a careful weighing of all the factors that become relevant in each particular case. The benefits, which reasonably may be expected to accrue from the proposal, must be balanced against its reasonably foreseeable detriments. The outcome of the general balancing process would determine whether to authorize a proposal, and if so, the conditions under which it will be allowed to occur. The decision should reflect the national concern for both protection and utilization of important resources. All factors, which may be relevant to the proposal, must be considered including the cumulative effects thereof. Among those are conservation, economics, aesthetics, general environmental concerns, wetlands, cultural values, fish and wildlife values, flood hazards, floodplain values, land use, navigation, shore erosion and accretion, recreation, water supply and conservation, water quality, energy needs, safety, food and fiber production, mineral needs, considerations of property ownership, and, in general, the needs and welfare of the people. For activities involving 404 discharges, a permit will be denied if the discharge that would be authorized by such permit would not comply with the Environmental Protection Agency's 404(b)(1) guidelines. Subject to the preceding sentence and any other applicable guidelines or criteria (see Sections 320.2 and 320.3), a permit will be granted unless the District Commander determines that it would be contrary to the public interest.

The Corps is soliciting comments from the public; Federal, State, and local agencies and officials; Indian Tribes; and other interested parties in order to consider and evaluate the impacts of this proposed activity. Any comments received will be considered by the Corps to determine whether to issue, modify, condition, or deny a permit for this proposal. To make this decision, comments are used to assess impacts on endangered species, historic properties, water quality, general environmental effects, and the other public interest factors listed above. Comments are used in the preparation of an Environmental Assessment and/or an Environmental Impact Statement pursuant to the National Environmental Policy Act. Comments are also used to determine the need for a public hearing and to determine the overall public interest of the proposed activity.

AUTHORITY: This permit will be issued or denied under the following authorities:

(X) Perform work in or affecting navigable waters of the United States – Section 10 Rivers and Harbors Act 1899 (33 U.S.C. 403).

(X) Discharge dredged or fill material into waters of the United States – Section 404 Clean Water Act (33 U.S.C. 1344). Therefore, our public interest review will consider the guidelines set forth under Section 404(b) of the Clean Water Act (40 CFR 230).

Project drawings are enclosed with this public notice.

District Commander
U.S. Army, Corps of Engineers

Enclosures

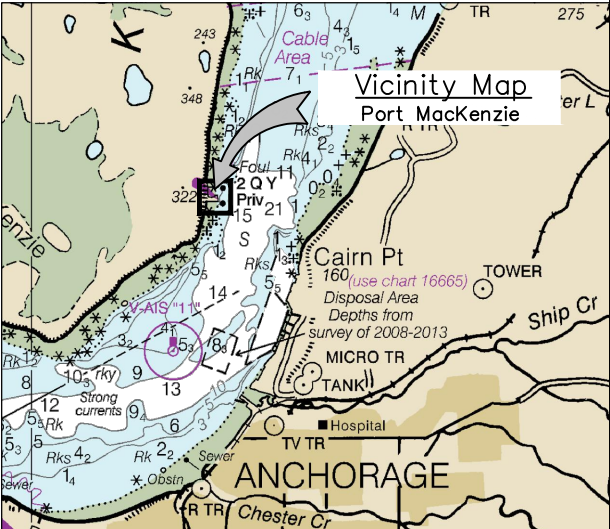
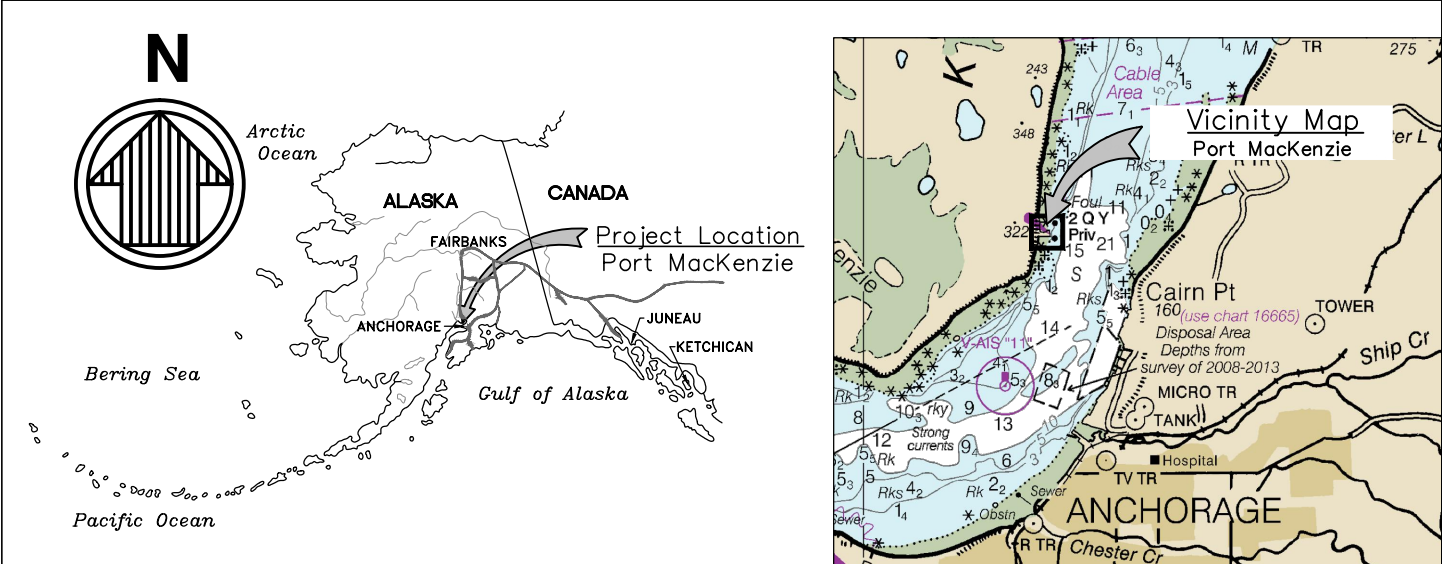

TIDAL DATA - ANCHORAGE, ALASKA (NOAA 9455920)

HIGH TIDE LINE (USACE)	35.2'
MEAN HIGHER HIGH WATER (MHHW)	29.16'
MEAN HIGH WATER (MHW)	28.43'
MEAN SEA LEVEL (MSL)	16.47'
MEAN LOW WATER (MLW)	2.25'
MEAN LOWER LOW WATER (MLLW)	0.00'
EXTREME LOW WATER	-6.39'

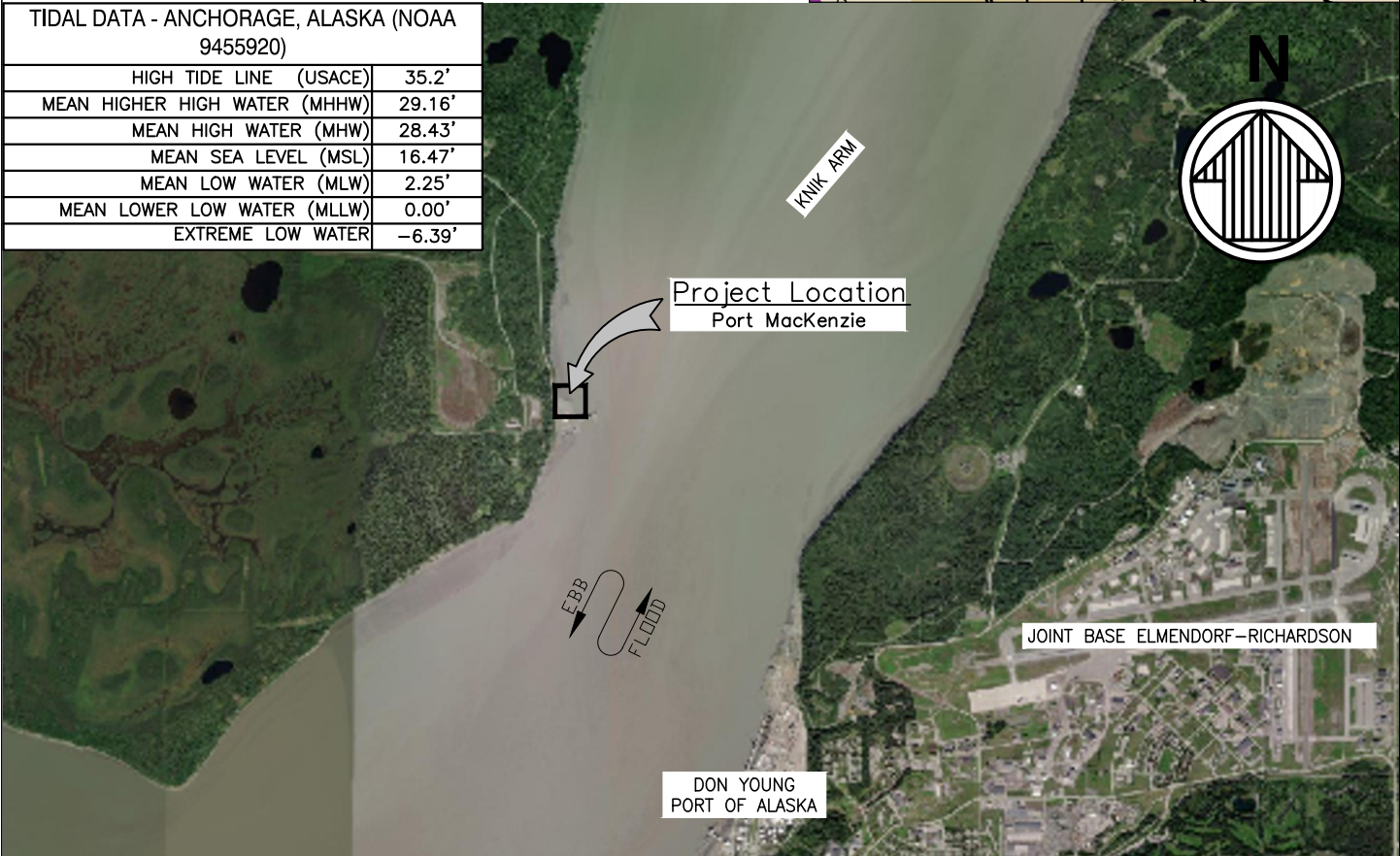

1 SITE PLAN
1 SCALE: N.T.S.

PURPOSE:
CONSTRUCT GRAVEL BARGE RAMP

PERMIT: POA-1979-00413

DATUM: M.L.L.W. = 0.0'

ADJACENT PROPERTY OWNERS:
UPLANDS: MAT-SU BOROUGH
OFFSHORE: ADNDR

VICINITY MAP

SCALE: NOT TO SCALE

MATANUSKA-SUSITNA BOROUGH
350 E. DAHLIA AVE.
PALMER, ALASKA 99645

PORT MACKENZIE BARGE HAULOUT
SEC. 25 T. 14N R. 4W M. SEWARD
WATERWAY: KNIK ARM
LAT.: 61.26975° LONG.: -149.91896°
APPLICATION BY:
MATANUSKA-SUSITNA BOROUGH
350 E. DAHLIA AVE.
PALMER, ALASKA 99645
SHEET: 1 OF 5 DATE: 03/17/25

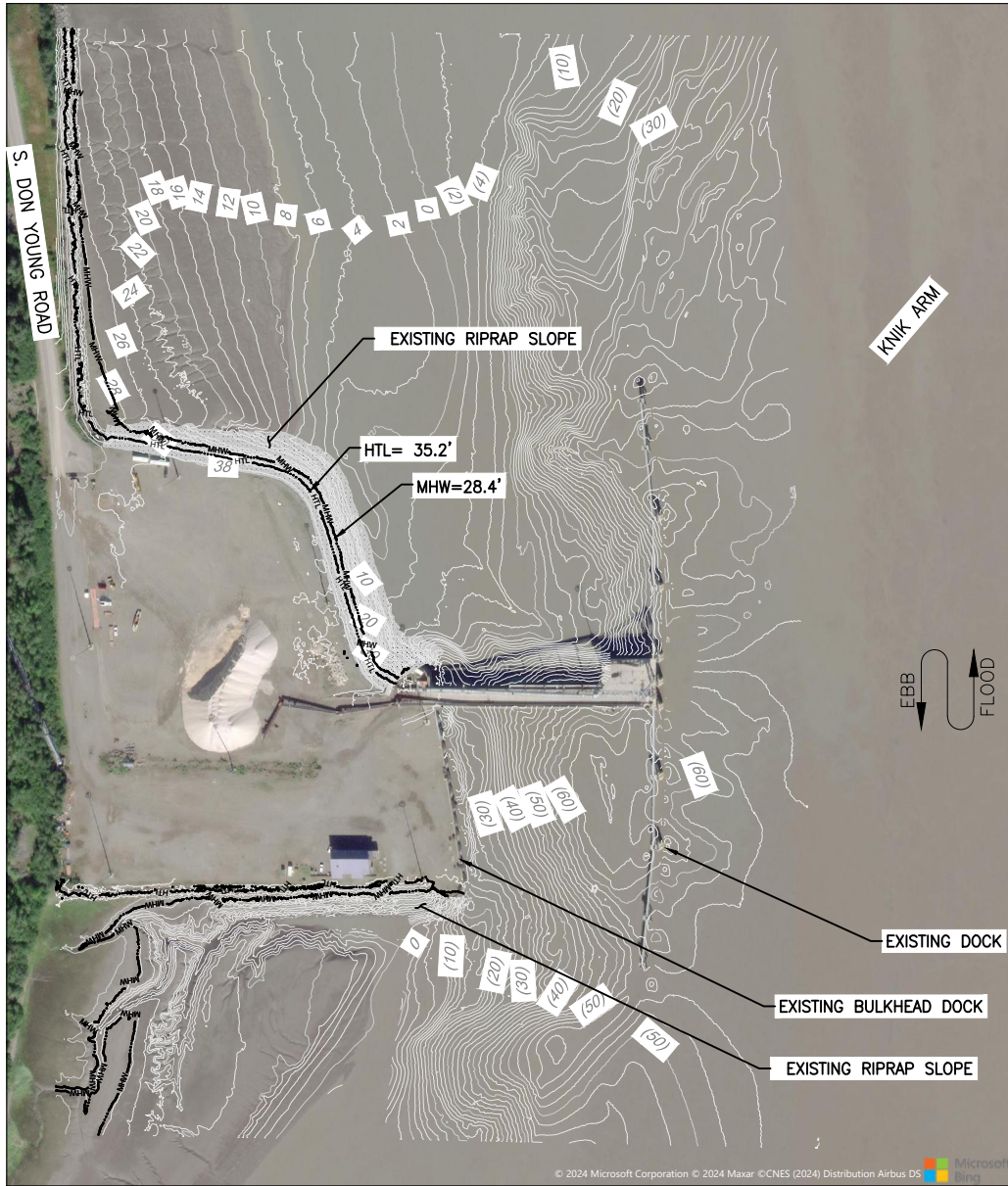
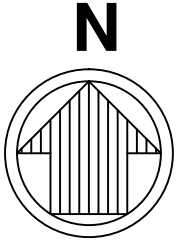

© 2024 Microsoft Corporation © 2024 Maxar © CNES (2024) Distribution Airbus DS Microsoft Bing

\\mme.net\projects\AK\220196-01\20 CADD\Active\Exhibits\USACE Permit Figures\P2 Exist Site.dwg

PURPOSE:
CONSTRUCT GRAVEL BARGE RAMP

PERMIT: POA-1979-00413

DATUM: M.L.L.W. = 0.0'

ADJACENT PROPERTY OWNERS:
UPLANDS: MAT-SU BOROUGH
OFFSHORE: ADNR



MATANUSKA-SUSITNA BOROUGH
350 E. DAHLIA AVE.
PALMER, ALASKA 99645

PORT MACKENZIE BARGE HAULOUT

SEC. 25 T. 14N R. 4W M. SEWARD
WATERWAY: KNIK ARM
LAT.: 61.26975° LONG.: -149.91896°

APPLICATION BY:
MATANUSKA-SUSITNA BOROUGH
350 E. DAHLIA AVE.
PALMER, ALASKA 99645

SHEET: 2 OF 5 DATE: 03/17/25

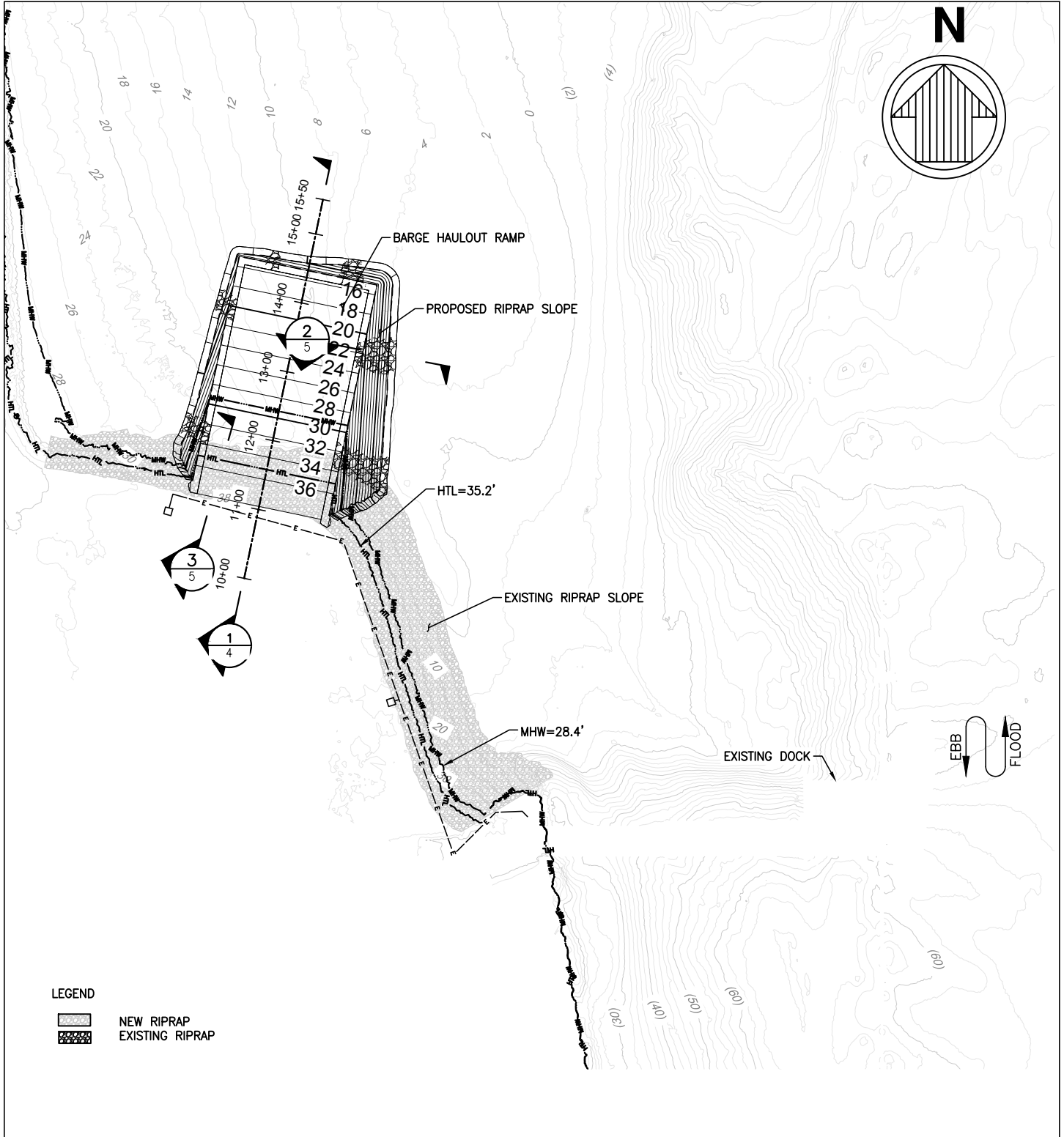

LEGEND
 NEW RIPRAP
 EXISTING RIPRAP

PURPOSE:
 CONSTRUCT GRAVEL BARGE RAMP
PERMIT: POA-1979-00413
DATUM: M.L.L.W. = 0.0'
ADJACENT PROPERTY OWNERS:
 UPLANDS: MAT-SU BOROUGH
 OFFSHORE: ADN R

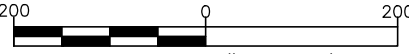
PROPOSED LAYOUT

 SCALE: 1" = 200'
 MATANUSKA-SUSITNA BOROUGH
 350 E. DAHLIA AVE.
 PALMER, ALASKA 99645

PORT MACKENZIE BARGE HAULOUT
 SEC. 25 T. 14N R. 4W M. SEWARD
 WATERWAY: KNIK ARM
 LAT.: 61.26975° LONG.: -149.91896°
 APPLICATION BY:
 MATANUSKA-SUSITNA BOROUGH
 350 E. DAHLIA AVE.
 PALMER, ALASKA 99645
 SHEET: 3 OF 5 DATE: 03/17/25

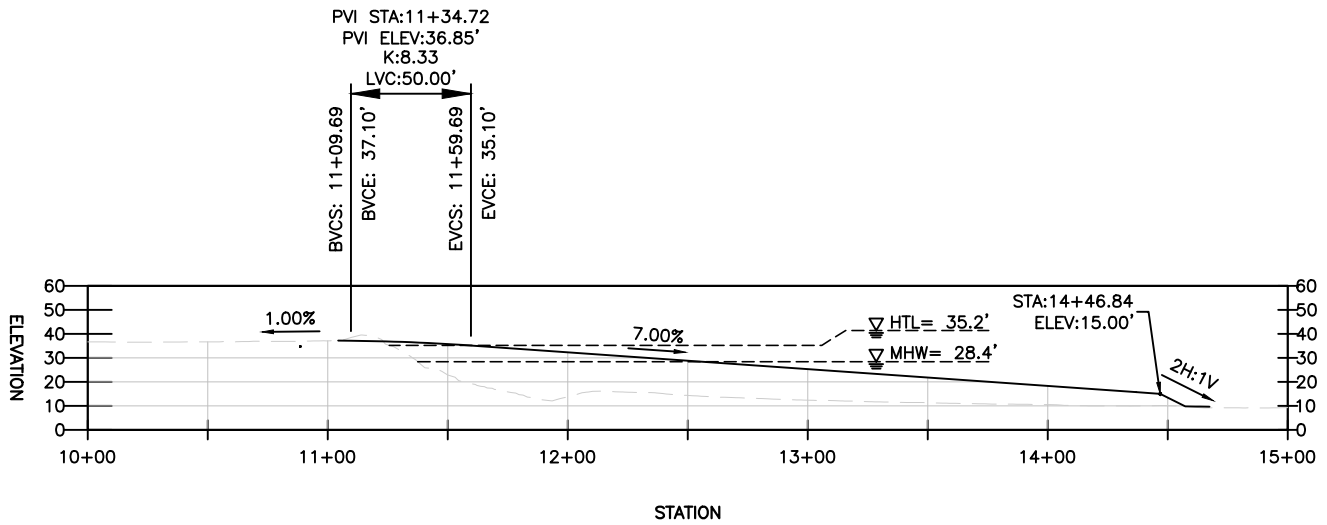
\\mne.net\projects\AK\220196-01\20 CADD\Active\Exhibits\USACE Permit Figures\P3 PROPOSED LAOYOUT.dwg.



1 SECTION - RAMP PROFILE
3 SCALE: N.T.S.

\\mme.net\projects\AK\220196-01\20 CADD\Active\Exhibits\USACE Permit Figures\P4-Ramp profile.dwg.

<p>PURPOSE: CONSTRUCT GRAVEL BARGE RAMP</p> <p>PERMIT: POA-1979-00413</p> <p>DATUM: M.L.L.W. = 0.0'</p> <p>ADJACENT PROPERTY OWNERS: UPLANDS: MAT-SU BOROUGH OFFSHORE: ADNDR</p>	<p>SECTION - RAMP PROFILE</p> <p>SCALE: NOT TO SCALE</p> <p>MATANUSKA-SUSITNA BOROUGH 350 E. DAHLIA AVE. PALMER, ALASKA 99645</p>	<p>PORT MACKENZIE BARGE HAULOUT SEC. 25 T. 14N R. 4W M. SEWARD WATERWAY: KNIK ARM LAT.: 61.26975° LONG.: -149.91896° APPLICATION BY: MATANUSKA-SUSITNA BOROUGH 350 E. DAHLIA AVE. PALMER, ALASKA 99645 SHEET: 4 OF 5 DATE: 03/17/25</p>
---	--	---

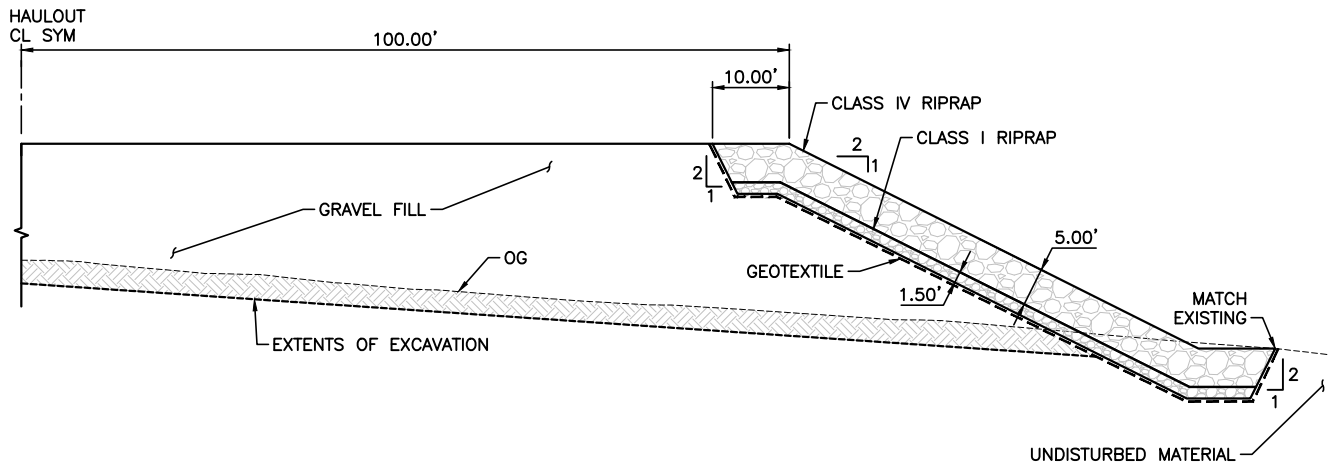

2 SECTION - TYPICAL RAMP SECTION
3 SCALE: N.T.S.

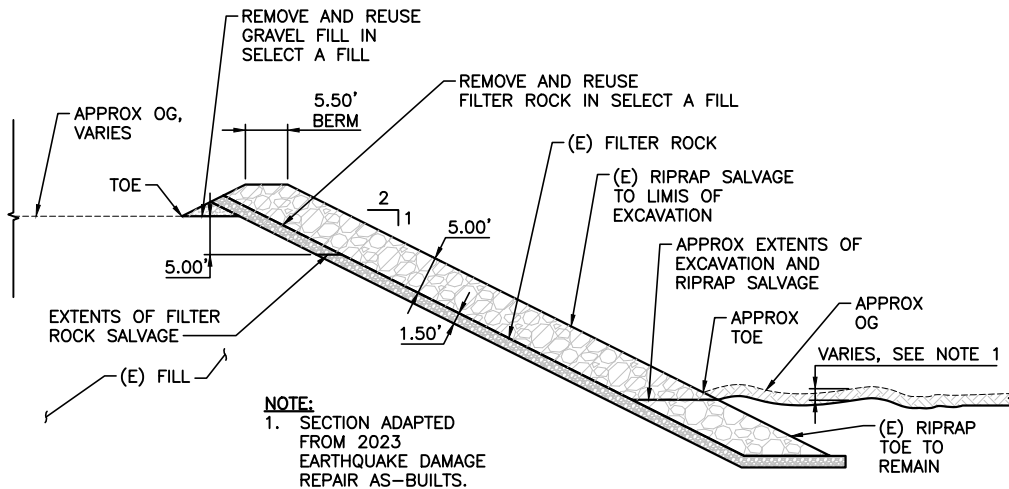

3 SECTION - TYPICAL EXISTING SECTION
3 SCALE: N.T.S.

PURPOSE:
CONSTRUCT GRAVEL BARGE RAMP

PERMIT: POA-1979-00413

DATUM: M.L.L.W. = 0.0'

ADJACENT PROPERTY OWNERS:
UPLANDS: MAT-SU BOROUGH
OFFSHORE: ADNOR

TYPICAL SECTIONS

SCALE: NOT TO SCALE

MATANUSKA-SUSITNA BOROUGH
350 E. DAHLIA AVE.
PALMER, ALASKA 99645

PORT MACKENZIE BARGE HAULOUT

SEC. 25 T. 14N R. 4W M. SEWARD

WATERWAY: KNIK ARM

LAT.: 61.26975° LONG.: -149.91896°

APPLICATION BY:

MATANUSKA-SUSITNA BOROUGH

350 E. DAHLIA AVE.

PALMER, ALASKA 99645

SHEET: 5 OF 5 DATE: 03/17/25