



US Army Corps
of Engineers
Alaska District

Public Notice of Application for Permit

Juneau Field Office
Regulatory Division (1145)
CEPOA-RD
8800 Glacier Highway, Suite 106
Juneau, Alaska 99801-8079

PUBLIC NOTICE DATE: June 4, 2012
EXPIRATION DATE: July 3, 2012
REFERENCE NUMBER: POA-2012-275
WATERWAY: Lutak Inlet

Interested parties are hereby notified that a Department of the Army permit application has been received for work in waters of the United States as described below and shown on the enclosed project drawings.

Comments on the described work, with the reference number, should reach this office no later than the expiration date of this Public Notice to become part of the record and be considered in the decision. Please contact **Randal Vigil** at (907) 790-4491, by fax at (907) 790-4497, or by email at **Randal.P.Vigil@usace.army.mil** if further information is desired concerning this notice.

APPLICANT: Alaska Department of Transportation and Public Facilities, 6860 Glacier Highway, Juneau, AK 99811.

LOCATION: The project site is located within Section 10, T. 30 S., R. 58 E., Copper River Meridian; USGS Quad Map Skagway B-2; Latitude 59.283° N., Longitude 135.466° W.; 2112 Lutak Road; Ferry Terminal, in Haines, Alaska.

PURPOSE: The applicant's stated purpose is to "improve public and vessel safety and enhance terminal operations".

PROPOSED WORK: The applicant requests authorization for the following work in waters and navigable waters of the United States:

1. Dredge approximately 10,000 cubic yards of marine sediment from approximately 0.7 acres below the plane of the high tide line (approximate elevation +21.2 feet above the 0.0 foot contour) (HTL) and mean high water mark (approximate elevation +15.8 feet above the 0.0 foot contour) (MHW) to provide sufficient water depth for ferry vessels at all tidal ranges.
2. Discharge approximately 35,000 cubic yards of armor rock and granular fill material into approximately 1.5 acres below the HTL to facilitate the expansion of the ferry terminal vehicle staging area.

3. Discharge fill material below the HTL in waters of the United States to facilitate the excavation of approximately 50,000 cubic yards of granular fill material to facilitate the removal of 4 existing sheet pile cells and associated timber fendering. Once the existing cells are removed side-slopes would be re-contoured, which would include the discharge of approximately 5,000 cubic yards of riprap into approximately 0.8 acres below the HTL to provide slope protection.

4. Install below the MHW approximately twenty 30-inch diameter piles to facilitate the construction of 5 mooring dolphins and associated catwalk to provide vessel moorage.

All work would be performed in accordance with the enclosed plan (sheets 1-8), dated Feb. 2012.

ADDITIONAL INFORMATION: The applicant submitted to the Corps of Engineers a sediment characterization and analysis report dated April 2010, for the above referenced proposed dredging and sheet pile cell removal. According to the applicant's report, no historical or present contamination exists at the proposed dredge and cell removal site. The dredged material and sheet pile cell embankment would be used as fill material for the proposed vehicle staging area expansion. Any excess material not incorporated into the proposed project would be disposed of at an approved upland area.

A determination of suitability of the dredged marine sediment and sheet pile cell material for discharge into waters of the United States will be made in consultation with the State and Federal agencies.

APPLICANT PROPOSED MITIGATION: The applicant proposes the following mitigation measures to avoid, minimize, and compensate for impacts to waters of the United States from activities involving discharges of dredged or fill material.

a. Avoidance: The applicant is not able to entirely avoid impacts to waters of the United States.

b. Minimization: "The following measures would be incorporated into the proposed project:

- Armor rock will be placed at the steepest slope angle practicable to reduce the fill footprint (2:1).
- Removal of the deteriorated sheet pile dock structure will convert approximately 0.8 acres of filled tidelands to open water marine habitat.
- Work in waters of the U.S. will be conducted in accordance with the terms and conditions of the Corps of Engineers permit.
- Placement of rip rap and fill will occur during lower tidal cycles to avoid or minimize in-water work. Rip rap used for the authorized work will be clean, free from pollution in toxic amounts. Rip rap will be free of fine sediments to the extent practicable, to reduce suspended material from entering the water column during tidal cycles.
- The Contractor will prepare a Hazardous Materials Control plan (HCMP) for handling, storage, cleanup, and disposal of petroleum products and hazardous materials needed for the project. The Contractor will provide and maintain a hazardous waste clean-up kit on-site at all times.
- The Contractor will be required to prepare and submit a Stormwater Pollution Prevention Plan (SWPPP) prior to any construction activities in accordance with standard DOT&PF design and construction requirements. The SWPPP will incorporate Best Management Practices (BMPs) to prevent erosion and control sediment release to water.

- All steel piles will be driven using a vibratory hammer. Under those conditions where impact hammers are required for reasons of seismic stability or substrate type, the piles will be driven as deep as possible with a vibratory hammer prior to the use of an impact hammer. A pile cushion will be used between the impact hammer and the piling to attenuate sound.
- Some or all of the steel piling on this project is expected to require installation into a drilled rock socket in shallow bedrock subsurface conditions. In these cases, the pile can be driven into the rock socket with a vibratory hammer.
- To reduce the possibility of direct mortality to migrating juvenile salmon and Chinook smolts in nearby net pens, pile driving will be avoided between April 15 and June 30."

c. Compensatory Mitigation: "DOT&PF proposes an in-lieu fee ratio of 1.5 to 1 for loss of 1.5 acres of intertidal habitat in accord with USACE Regulatory Guidance Letter 09-01 because the loss of moderate value intertidal habitat will be partially replaced by high value intertidal habitat (App. B of USACE RGL 09-01). That is:

- The 1.5 acres intertidal substrate has an unvegetated rocky, cobbly, bottom; a moderate value habitat, and
- 0.8 acre of intertidal habitat will be restored on-site by providing an armor rock slope.
- The armor rock provides a medium for marine vegetation to grow, and interstitial spaces for migrating salmonids, high value habitat.

Total compensatory mitigation will be a purchase of in-lieu fee preservation credits for 2.25 acres."

WATER QUALITY CERTIFICATION: A permit for the described work will not be issued until a certification or waiver of certification, as required under Section 401 of the Clean Water Act (Public Law 95-217), has been received from the Alaska Department of Environmental Conservation.

CULTURAL RESOURCES: The latest published version of the Alaska Heritage Resources Survey (AHRS) has been consulted for the presence or absence of historic properties, including those listed in or eligible for inclusion in the National Register of Historic Places. There are no listed or eligible properties in the vicinity of the worksite. Consultation of the AHRS constitutes the extent of cultural resource investigations by the District Commander at this time, and he is otherwise unaware of the presence of such resources. This application is being coordinated with the State Historic Preservation Office (SHPO). Any comments SHPO may have concerning presently unknown archeological or historic data that may be lost or destroyed by work under the requested permit will be considered in our final assessment of the described work.

ENDANGERED SPECIES: The project area is within the known or historic range of the Humpback whale (*Megaptera novaeangliae*) and Steller sea lion (*Eumetopias jubatus*).

However, with the inclusion of the applicant's above listed measures to minimize impacts to the aquatic environment, we have determined the described activity would have no effect on the Humpback whale or the Steller sea lion, and would have no effect on any designated or proposed critical habitat, under the Endangered Species Act of 1973 (87 Stat. 844). Therefore, no consultation with the U.S. Fish and Wildlife Service or the National Marine Fisheries Service is required. However, any comments they may have concerning endangered or threatened wildlife or plants or their critical habitat will be considered in our final assessment of the described work.

MARINE MAMMALS: The Corps will consider impacts to marine mammals in accordance with the Marine Mammal Protection Act. In addition to the species listed in the Endangered Species section above, the described activity may affect the harbor seal (*Phoca vitulina*), the Orca (*Orcinus orca*), Minke Whale (*Balaenoptera acutorostrata*), and the Pacific White-sided Dolphin (*Lagenorhynchus obliquidens*).

This application is being coordinated with the NMFS. Any comments the agency may have concerning protected marine mammals will be considered in our final assessment of the described work.

ESSENTIAL FISH HABITAT: The Magnuson-Stevens Fishery Conservation and Management Act, as amended by the Sustainable Fisheries Act of 1996, requires all Federal agencies to consult with the NMFS on all actions, or proposed actions, permitted, funded, or undertaken by the agency, that may adversely affect Essential Fish Habitat (EFH).

The project area is within the known range of the Chinook (*Oncorhynchus tshawytscha*), chum (*Oncorhynchus keta*), Coho (*Oncorhynchus kisutch*), pink (*Oncorhynchus gorbuscha*), and sockeye (*Oncorhynchus nerka*) salmon.

We have determined the described activity may adversely affect EFH in the project area for the following species chum (*Oncorhynchus keta*), Coho (*Oncorhynchus kisutch*), pink (*Oncorhynchus gorbuscha*), and sockeye (*Oncorhynchus nerka*) salmon. The proposed project location is nearshore shallow water habitat primarily for adult and juvenile salmon migration, as these waters provide refuge from predators and opportunity to rest. The proposed project would involve pile driving, dredging, and filling activities, which may increase the potential for injury or mortality to salmon from pressure waves generated from pile driving, elevation of suspended particulates within the water column, and/or loss of habitat.

An EFH assessment was prepared for the proposed project that determined the described activity would have a temporary adverse effect on EFH during construction. However, adverse impacts from construction activities would not be substantial because of the timing window for construction and proposed mitigation measures. Although 1.5 acres of land below the HTL would be lost southeast of the existing terminal as a result of the proposed project, approximately 0.8 acres of fish habitat (riprap slope) would be created in an area of previously filled tideland. The long-term effects on EFH would be minimal from the permanent loss of 0.7 acres of intertidal habitat.

This Public Notice initiates EFH consultation with the NMFS. Any comments or recommendations they may have concerning EFH will be considered in our final assessment of the described work.

TRIBAL CONSULTATION: The Alaska District fully supports tribal self-governance and government-to-government relations between Federally recognized Tribes and the Federal government. Tribes with protected rights or resources that could be significantly affected by a proposed Federal action (e.g., a permit decision) have the right to consult with the Alaska District on a government-to-government basis. Views of each Tribe regarding protected rights and resources will be accorded due consideration in this process. This Public Notice serves as notification to the Tribes within the area potentially affected by the proposed work and invites their participation in the Federal decision-making process regarding the protected Tribal right or resource. Consultation may be initiated by the affected Tribe upon written request to the District Commander during the public comment period.

PUBLIC HEARING: Any person may request, in writing, within the comment period specified in this notice, that a public hearing be held to consider this application. Requests for public hearings shall state, with particularity, reasons for holding a public hearing.

EVALUATION: The decision whether to issue a permit will be based on an evaluation of the probable impacts, including cumulative impacts of the proposed activity and its intended use on the public interest. Evaluation of the probable impacts, which the proposed activity may have on the public interest, requires a careful weighing of all the factors that become relevant in each particular case. The benefits, which reasonably may be expected to accrue from the proposal, must be balanced against its reasonably foreseeable detriments. The outcome of the general balancing process would determine whether to authorize a proposal, and if so, the conditions under which it will be allowed to occur. The decision should reflect the national concern for both protection and utilization of important resources. All factors, which may be relevant to the proposal, must be considered including the cumulative effects thereof. Among those are conservation, economics, aesthetics, general environmental concerns, wetlands, cultural values, fish and wildlife values, flood hazards, floodplain values, land use, navigation, shore erosion and accretion, recreation, water supply and conservation, water quality, energy needs, safety, food and fiber production, mineral needs, considerations of property ownership, and, in general, the needs and welfare of the people. For activities involving 404 discharges, a permit will be denied if the discharge that would be authorized by such permit would not comply with the Environmental Protection Agency's 404(b)(1) guidelines. Subject to the preceding sentence and any other applicable guidelines or criteria (see Sections 320.2 and 320.3), a permit will be granted unless the District Commander determines that it would be contrary to the public interest.

The Corps of Engineers is soliciting comments from the public; Federal, State, and local agencies and officials; Indian Tribes; and other interested parties in order to consider and evaluate the impacts of this proposed activity. Any comments received will be considered by the Corps of Engineers to determine whether to issue, modify, condition or deny a permit for this proposal. To make this decision, comments are used to assess impacts on endangered species, historic properties, water quality, general environmental effects, and the other public interest factors listed above. Comments are used in the preparation of an Environmental Assessment and/or an Environmental Impact Statement pursuant to the National Environmental Policy Act. Comments are also used to determine the need for a public hearing and to determine the overall public interest of the proposed activity.

AUTHORITY: This permit will be issued or denied under the following authorities:

(X) Perform work in or affecting navigable waters of the United States -
Section 10 Rivers and Harbors Act 1899 (33 U.S.C. 403).

(X) Discharge dredged or fill material into waters of the United States -
Section 404 Clean Water Act (33 U.S.C. 1344). Therefore, our public interest review will consider the guidelines set forth under Section 404(b) of the Clean Water Act (40 CFR 230).

Project drawings and a Notice of Application for State Water Quality Certification are enclosed with this Public Notice.

District Commander
U.S. Army, Corps of Engineers

Enclosures

STATE OF ALASKA

DEPT. OF ENVIRONMENTAL CONSERVATION
DIVISION OF WATER
401 Certification Program
Non-Point Source Water Pollution Control Program

Department of Environmental Conservation
WQM/401 Certification
410 Willoughby Avenue
Juneau, Alaska 99801-1795
Phone: (907) 465-5321/Fax: (907) 465-5274

NOTICE OF APPLICATION
FOR
STATE WATER QUALITY CERTIFICATION

Any applicant for a federal license or permit to conduct an activity that might result in a discharge into navigable waters, in accordance with Section 401 of the Clean Water Act of 1977 (PL95-217), also must apply for and obtain certification from the Alaska Department of Environmental Conservation that the discharge will comply with the Clean Water Act, the Alaska Water Quality Standards, and other applicable State laws. By agreement between the U.S. Army Corps of Engineers and the Department of Environmental Conservation, application for a Department of the Army permit to discharge dredged or fill material into navigable waters under Section 404 of the Clean Water Act also may serve as application for State Water Quality Certification.

Notice is hereby given that the application for a Department of the Army Permit described in the Corps of Engineers' Public Notice No. POA-2012-275, Lutak Inlet, serves as application for State Water Quality Certification from the Department of Environmental Conservation.

After reviewing the application, the Department may certify there is reasonable assurance the activity, and any discharge that might result, will comply with the Clean Water Act, the Alaska Water Quality Standards, and other applicable State laws. The Department also may deny or waive certification.

Any person desiring to comment on the project, with respect to Water Quality Certification, may submit written comments to the address above by the expiration date of the Corps of Engineer's Public Notice.

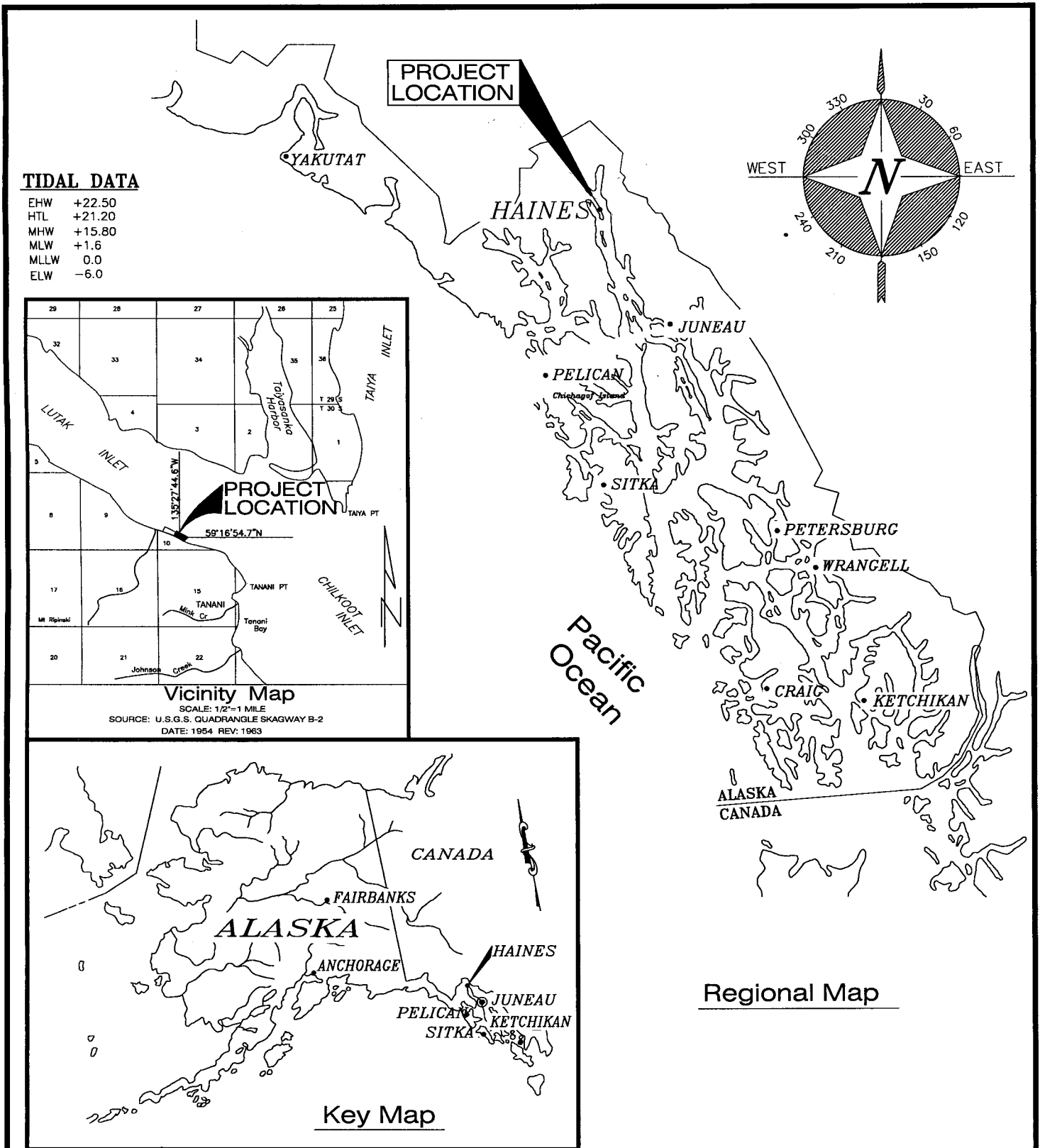

TIDAL DATA

EHW	+22.50
HTL	+21.20
MHW	+15.80
MLW	+1.6
MLLW	0.0
ELW	-6.0

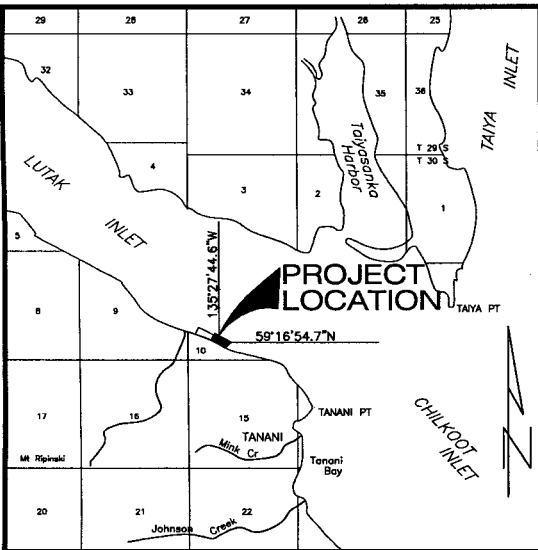

Vicinity Map

SCALE: 1/2"=1 MILE
 SOURCE: U.S.G.S. QUADRANGLE SKAGWAY B-2
 DATE: 1954 REV: 1963

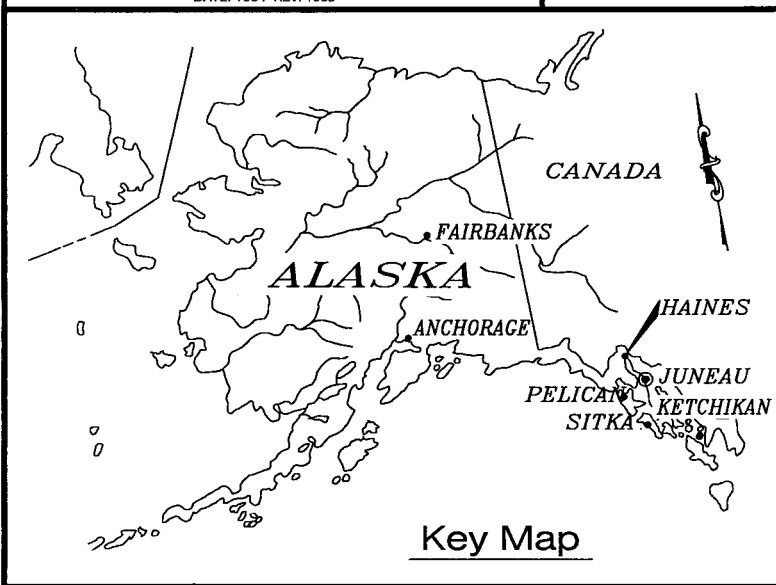

Key Map

Regional Map

PROJECT PURPOSE:
 FERRY TERMINAL IMPROVEMENTS

ADJACENT PROPERTY OWNER(S):
 STATE OF ALASKA
 CITY OF HAINES
 HERTZ/SCHAFFER

REGIONAL MAPS

APPLICATION BY:
 STATE OF ALASKA
 DEPT. OF TRANSPORTATION & PUBLIC FACILITIES
 SOUTHEAST REGION

HAINES FERRY TERMINAL IMPROVEMENTS
 PROJECT NO. 68433

AT: Haines, Alaska
LOCATED IN: Lutak Inlet
 Lat. 57° 16' 54.7" N
 Lng. 135° 27' 44.6 W

DATE: Feb 2012 **SHEET** 1 **OF** 8

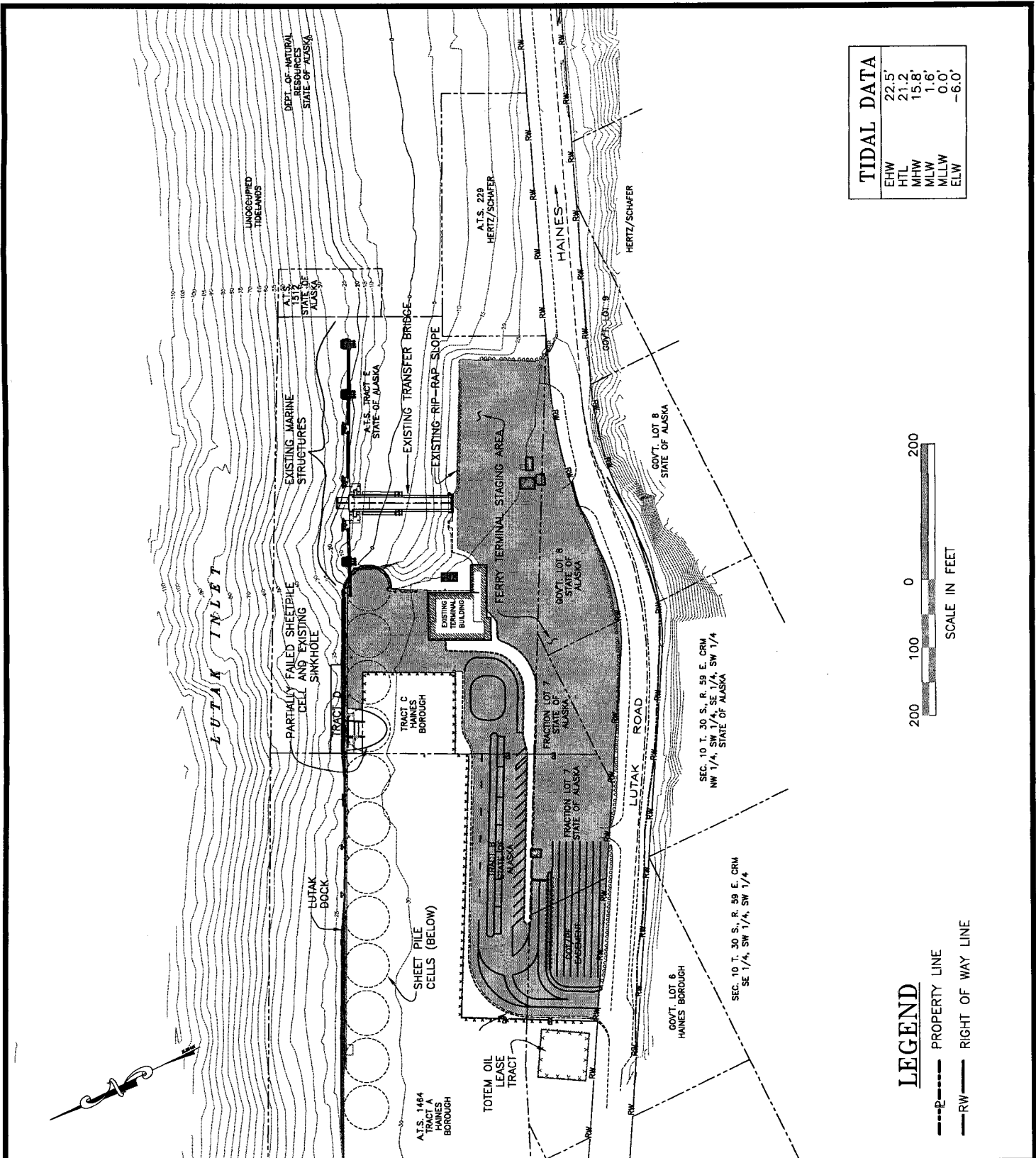

TIDAL DATA	
EHW	22.5'
HTL	21.2'
MHW	15.8'
MLW	1.6'
MLLW	0.0'
ELW	-6.0'

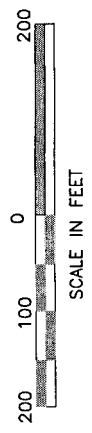

LEGEND
 - - - - - PROPERTY LINE
 ——— RIGHT OF WAY LINE

PROJECT PURPOSE:
 FERRY TERMINAL IMPROVEMENTS

ADJACENT PROPERTY OWNER(S):
 STATE OF ALASKA
 CITY OF HAINES
 HERTZ/SCHAFER

EXISTING SITE PLAN

APPLICATION BY:
 STATE OF ALASKA
 DEPT. OF TRANSPORTATION & PUBLIC FACILITIES
 SOUTHEAST REGION

HAINES FERRY TERMINAL IMPROVEMENTS
 PROJECT NO. 68433

AT: Haines, Alaska
LOCATED IN: Lutak Inlet
 Lat. 57° 16' 54.7" N
 Lng. 135° 27' 44.6" W

DATE: Feb 2012 **SHEET** 2 **OF** 8

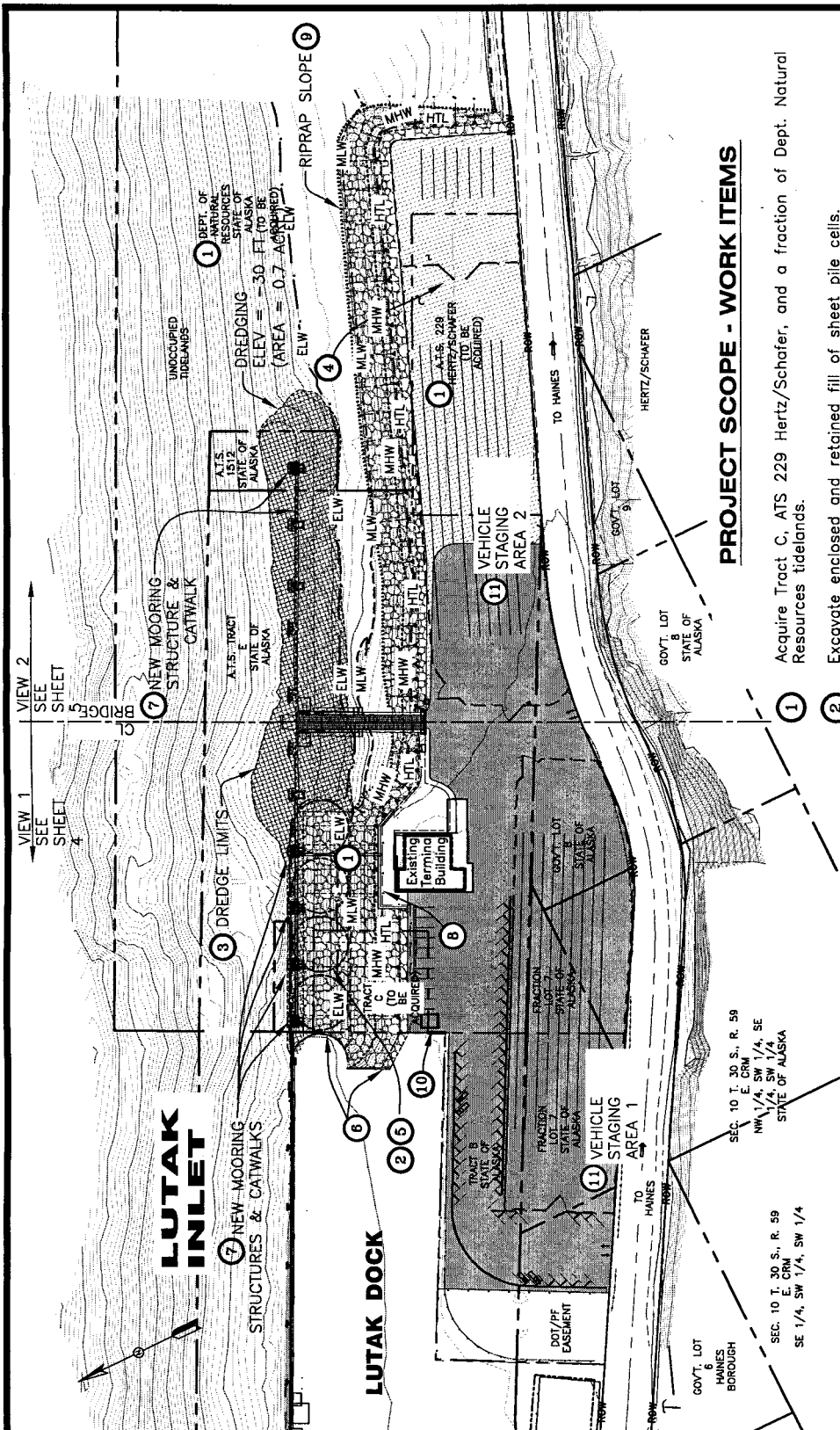

PROJECT SCOPE - WORK ITEMS

- 1 Acquire Tract C, ATS 229 Hertz/Schafer, and a fraction of Dept. Natural Resources tidelands.
- 2 Excavate enclosed and retained fill of sheet pile cells.
- 3 Dredge at existing berth.
- 4 Embank excavated and dredged materials to the east of existing staging area. Place concrete curb & gutter and asphalt paving.
- 5 Remove and dispose of four (4) sheet pile cells and associated fendering.
- 6 Erect retaining wall at east end of Lutak Dock and retrofit cap on Lutak Dock cell.
- 7 Install four (4) mooring structures and catwalks west of transfer bridge. Install one (1) mooring structure and catwalk east of transfer bridge.
- 8 Install concrete block retaining wall on north side of Terminal Building.
- 9 Armor slopes with riprap.
- 10 Relocate generator & storage building.
- 11 Reconfigure staging and parking areas to provide (2) separate vehicle staging areas.



Tidal Data	
EHW	22.5'
HTL	21.2'
MHW	15.8'
MLW	1.6'
MLLW	0.0'
ELW	-6.0'

LEGEND

- PROPERTY LINE
- RIGHT OF WAY LINE
- ARMOR ROCK
- DREDGE AREA
- NEW FILL AREA
- EXISTING FERRY TERMINAL UPLANDS

PROJECT PURPOSE:
FERRY TERMINAL IMPROVEMENTS

ADJACENT PROPERTY OWNER(S):
STATE OF ALASKA
CITY OF HAINES
HERTZ/SCHAFER

NEW SITE PLAN

APPLICATION BY:
STATE OF ALASKA
DEPT. OF TRANSPORTATION & PUBLIC FACILITIES
SOUTHEAST REGION

HAINES FERRY TERMINAL IMPROVEMENTS
PROJECT NO. 68433

AT: Haines, Alaska
LOCATED IN: Lutak Inlet
Lat. 57° 16' 54.7" N
Lng. 135° 27' 44.6 W

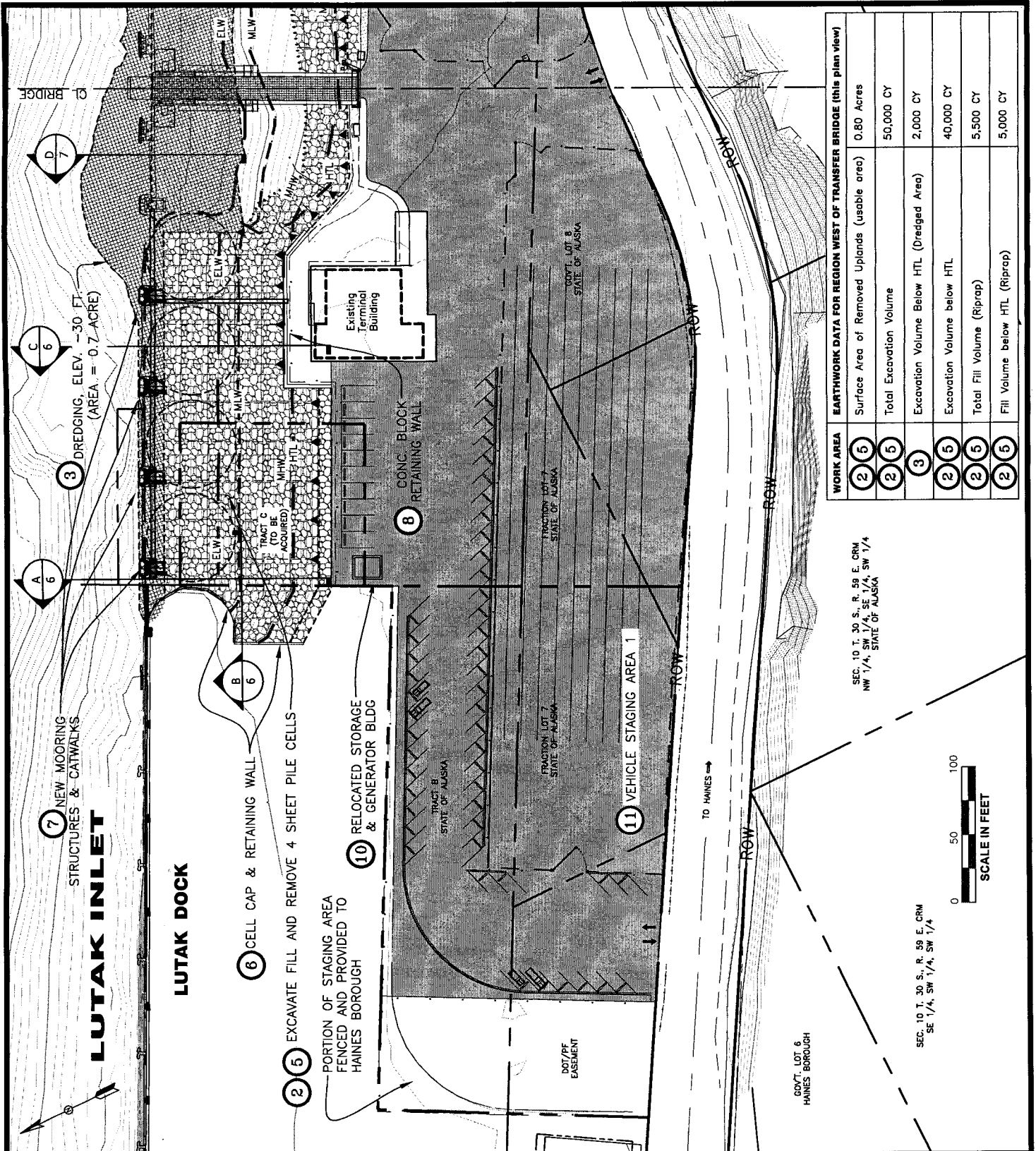

WORK AREA	EARTHWORK DATA FOR REGION WEST OF TRANSFER BRIDGE (this plan view)			
(2)(5)	Surface Area of Removed Uplands (usable area)	0.80 Acres		
(2)(5)	Total Excavation Volume	50,000 CY		
(3)	Excavation Volume Below HTL (Dredged Area)	2,000 CY		
(2)(5)	Excavation Volume below HTL	40,000 CY		
(2)(5)	Total Fill Volume (Riprap)	5,500 CY		
(2)(5)	Fill Volume below HTL (Riprap)	5,000 CY		

SEC. 10 T. 30 S., R. 59 E. CRM
NW 1/4, SW 1/4, SE 1/4, SW 1/4
STATE OF ALASKA

SEC. 10 T. 30 S., R. 59 E. CRM
SE 1/4, SW 1/4, SW 1/4
HAINES BOROUGH



PROJECT PURPOSE:
FERRY TERMINAL IMPROVEMENTS

ADJACENT PROPERTY OWNER(S):
STATE OF ALASKA
CITY OF HAINES
HERTZ/SCHAFER

VIEW 1 PLAN

APPLICATION BY:
STATE OF ALASKA
DEPT. OF TRANSPORTATION & PUBLIC FACILITIES
SOUTHEAST REGION

HAINES FERRY TERMINAL IMPROVEMENTS
PROJECT NO. 68433

AT: Haines, Alaska
LOCATED IN: Lutak Inlet
Lat. 57° 16' 54.7" N
Lng. 135° 27' 44.6" W

DATE: Feb 2012 SHEET 4 OF 8

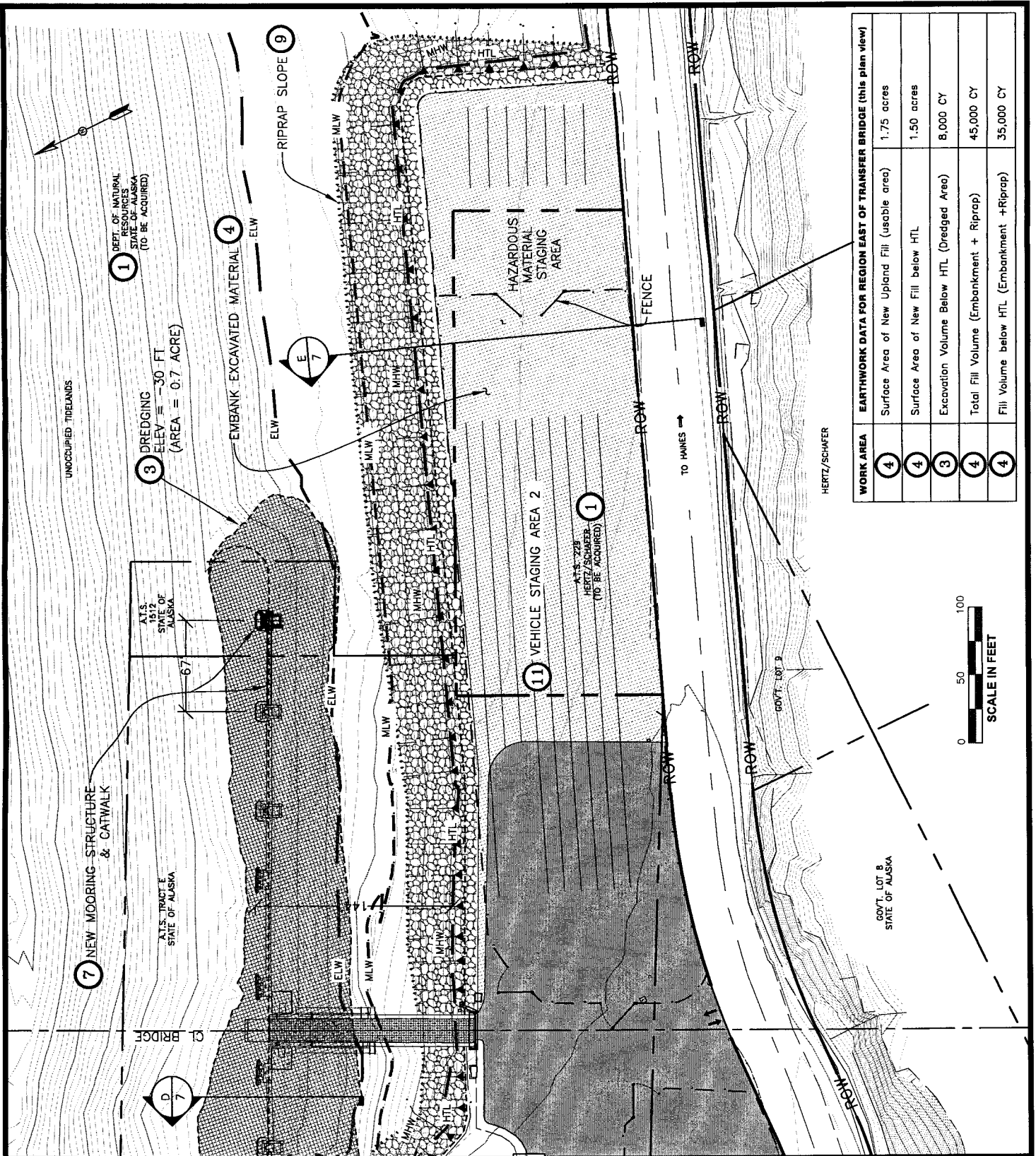

WORK AREA	EARTHWORK DATA FOR REGION EAST OF TRANSFER BRIDGE (this plan view)	
4	Surface Area of New Upland Fill (usable area)	1.75 acres
4	Surface Area of New Fill below HTL	1.50 acres
3	Excavation Volume Below HTL (Dredged Area)	8,000 CY
4	Total Fill Volume (Embankment + Riprap)	45,000 CY
4	Fill Volume below HTL (Embankment + Riprap)	35,000 CY

PROJECT PURPOSE:
FERRY TERMINAL IMPROVEMENTS

VIEW 2 PLAN

HAINES FERRY TERMINAL IMPROVEMENTS
PROJECT NO. 68433

ADJACENT PROPERTY OWNER(S):
STATE OF ALASKA
CITY OF HAINES
HERTZ/SCHAFFER

APPLICATION BY:
STATE OF ALASKA
DEPT. OF TRANSPORTATION & PUBLIC FACILITIES
SOUTHEAST REGION

AT: Haines, Alaska
LOCATED IN: Lutak Inlet
Lat. 57° 16' 54.7" N
Lng. 135° 27' 44.6" W

DATE: Feb 2012 **SHEET** 5 **OF** 8

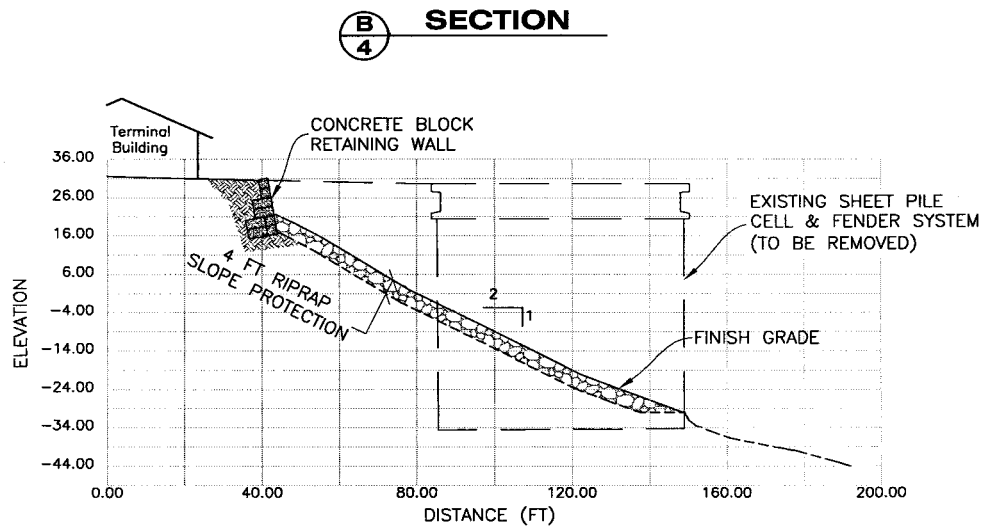
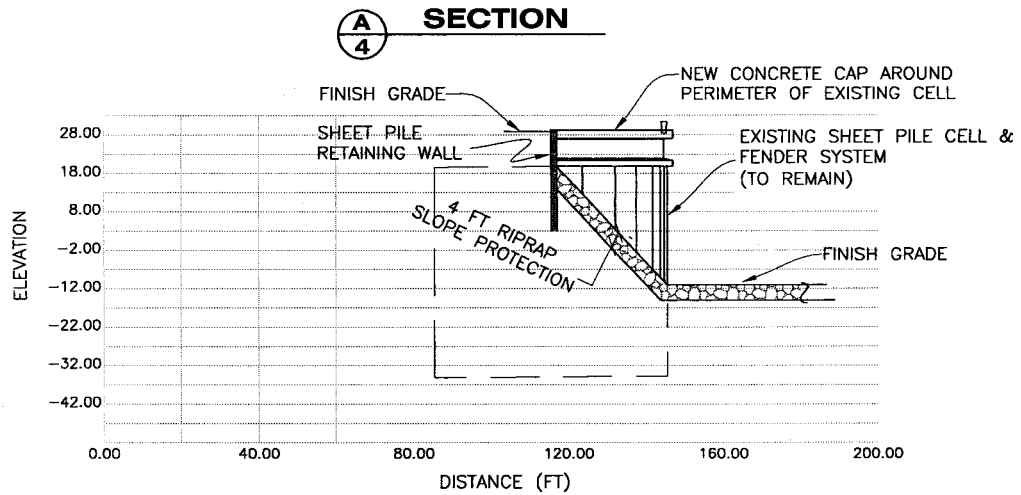
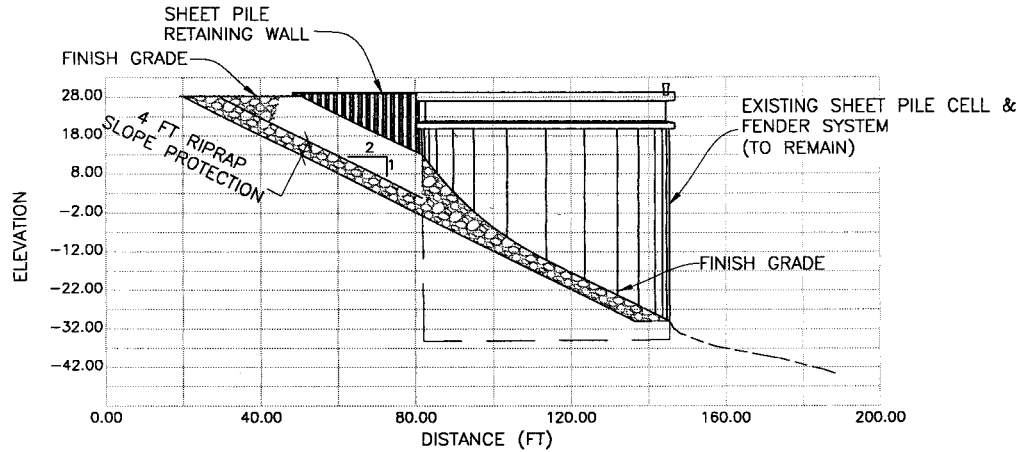

PROJECT PURPOSE:
FERRY TERMINAL IMPROVEMENTS

SECTIONS (1)

HAINES FERRY TERMINAL IMPROVEMENTS
PROJECT NO. 68433

ADJACENT PROPERTY OWNER(S):
STATE OF ALASKA
CITY OF HAINES
HERTZ/SCHAFFER

APPLICATION BY:
STATE OF ALASKA
DEPT. OF TRANSPORTATION & PUBLIC FACILITIES
SOUTHEAST REGION

AT: Haines, Alaska
LOCATED IN: Lutak Inlet
Lat. 57° 16' 54.7" N
Lng. 135° 27' 44.6 W

DATE: Feb 2012 **SHEET** 6 **OF** 8

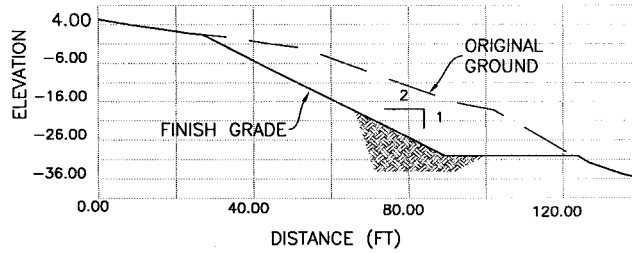

D
7 SECTION

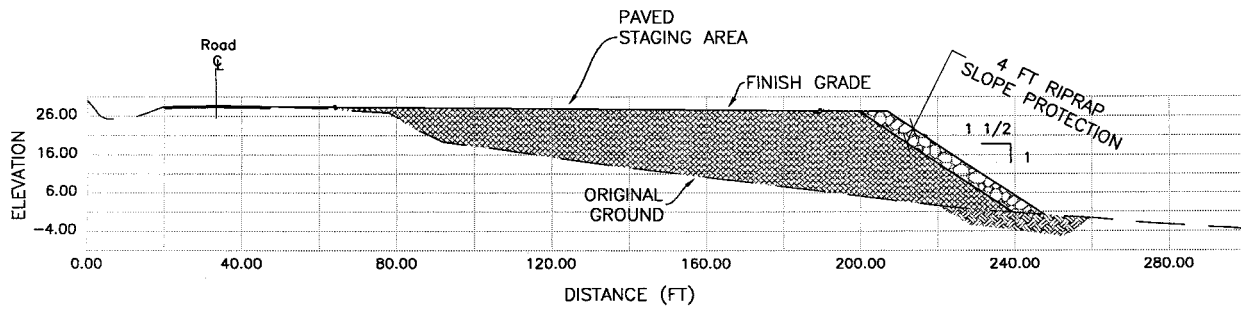

E
7 SECTION

PROJECT PURPOSE:
FERRY TERMINAL IMPROVEMENTS

SECTIONS (2)

HAINES FERRY TERMINAL IMPROVEMENTS
PROJECT NO. 68433

ADJACENT PROPERTY OWNER(S):
STATE OF ALASKA
CITY OF HAINES
HERTZ/SCHAFFER

APPLICATION BY:
STATE OF ALASKA
DEPT. OF TRANSPORTATION & PUBLIC FACILITIES
SOUTHEAST REGION

AT: Haines, Alaska
LOCATED IN: Lutak Inlet
Lat. 57° 16' 54.7" N
Lng. 135° 27' 44.6 W

DATE: Feb 2012 **SHEET** 7 **OF** 8

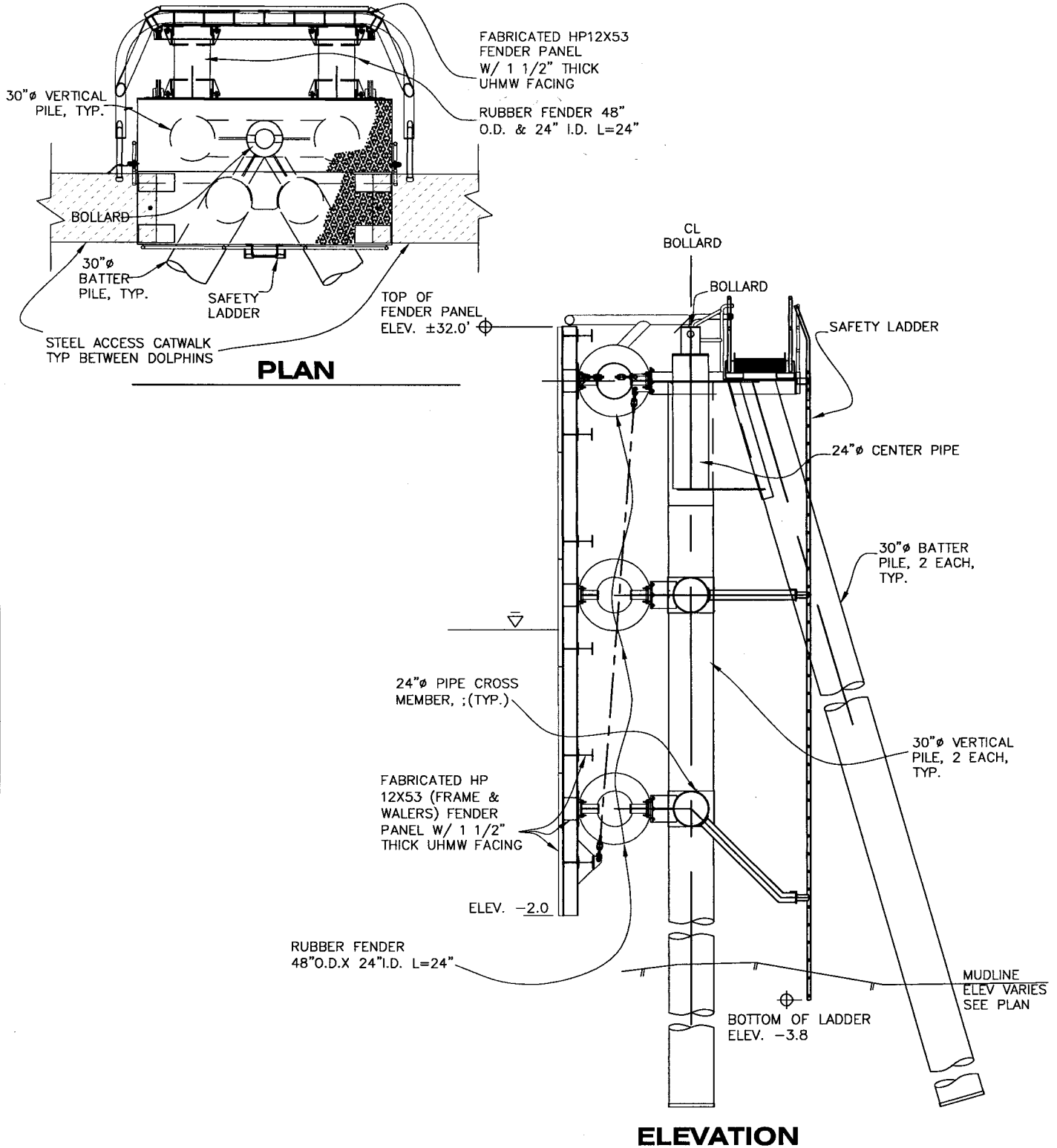

PROJECT PURPOSE:
FERRY TERMINAL IMPROVEMENTS

ADJACENT PROPERTY OWNER(S):
STATE OF ALASKA
CITY OF HAINES
HERTZ/SCHAFFER

TYPICAL MOORING DOLPHIN

APPLICATION BY:
STATE OF ALASKA
DEPT. OF TRANSPORTATION & PUBLIC FACILITIES
SOUTHEAST REGION

HAINES FERRY TERMINAL IMPROVEMENTS
PROJECT NO. 68433

AT: Haines, Alaska
LOCATED IN: Lutak Inlet
Lat. 57° 16' 54.7" N
Lng. 135° 27' 44.6 W

DATE: Feb 2012 **SHEET** 8 **OF** 8